



MINISTERIO
DE ECONOMÍA, INDUSTRIA
Y COMPETITIVIDAD

DIRECCIÓN GENERAL DE INDUSTRIA Y
DE LA PEQUEÑA Y MEDIANA EMPRESA
SUBDIRECCIÓN GENERAL DE
CALIDAD Y SEGURIDAD INDUSTRIAL



E9-05.1989

Ext.02

Página / Page 1/2

Comunicación sobre / *Concerning* ⁽¹⁾:

- ~~concesión de la homologación / *approval granted*~~
- ~~extensión de la homologación / *approval extended*~~
- ~~denegación de la homologación / *approval refused*~~
- ~~retirada de homologación / *approval withdrawn*~~
- ~~cese definitivo de la producción / *production definitely discontinued*~~

de un tipo de casco de protección con/sin ⁽¹⁾ uno/varios ⁽¹⁾ tipo(s) de pantalla en aplicación del Reglamento N° 22 /
of a type of protective helmet with/without ⁽¹⁾ one/more ⁽¹⁾ visor type(s) pursuant to Regulation No. 22.

Homologación n° / *Approval No.*: E9-05.1989

Extensión N° / *Extension No.* 02

Motivos de la extensión / *Reasons for extension*: Inclusión de nuevo cierre y cambio del PEE para todas las tallas /
Inclusion of new buckle and change of the EPS for all sizes

1. Marca de fábrica o comercial / *Trade mark*: MHR, LS2
2. Tipo / *Type*: FF352-1
3. Tallas / *Sizes*: XXS(52), XS(54), S(56), M(58), L(60), XL(61), XXL(61)
4. Nombre del fabricante / *Manufacturer's name*:
JIANGMEN PENGCHENG HELMETS LTD.
5. Dirección del fabricante / *Manufacturer's address*:
No.01-7 Dongsheng Road, Gonghe Town, Heshan, Jiangmen City,
Guangdong, 529728 P.R. China
6. Nombre del representante, en su caso / *If applicable, name of manufacturer's representative*: ----
7. Dirección del representante / *Representative address*: ----
8. Breve descripción del casco / *Brief description of helmet*:
Ver documentación del fabricante / *See manufacturer's documentation*
9. Casco ~~sin protección de barbilla (J)~~ / con protección de barbilla (P) / ~~con protección de barbilla no protectora (NP)~~ / *Helmet without lower face cover (J) / with protective lower face cover (P) / with non-protective lower face cover (NP)* ⁽¹⁾
10. Tipo de pantalla o pantallas / *Type of visor or visors*: FF-MHR-15 (E9-05.1551)
11. Breve descripción de la pantalla o pantallas / *Brief description of visor or visors*:
Ver documentación del fabricante / *See manufacturer's documentation*

⁽¹⁾ Táchese lo que no proceda / *Strike out what does not apply*



MINISTERIO
DE ECONOMÍA, INDUSTRIA
Y COMPETITIVIDAD

DIRECCIÓN GENERAL DE INDUSTRIA Y
DE LA PEQUEÑA Y MEDIANA EMPRESA
SUBDIRECCIÓN GENERAL DE
CALIDAD Y SEGURIDAD INDUSTRIAL



E9-05.1989

Ext.02

Página / Page 2/2

12. Presentado a la homologación el / *Submitted for approval on*: 18.06.2014, 24.09.2014, 25.10.2016
13. Servicio técnico encargado de los ensayos de homologación / *Technical service responsible for conducting approval tests*: IDIADA
14. Fecha del acta de los ensayos emitida por este servicio / *Date of report issued by that service*: 29.07.2014, 07.11.2014, 05.12.2016
15. Nº del acta de ensayos emitida por este servicio / *Number of report issued by that service*: MT14060075, MT14090083, MT16100097
16. Observaciones / *Comments*: ----
17. Homologación ~~concedida~~ / extendida / ~~denegada~~ / retirada ⁽¹⁾ / *Approval ~~granted~~ / extended / ~~refused~~ / withdrawn ⁽¹⁾*
18. Lugar / *Place*: Madrid
19. Fecha / *Date*: Ver firma electrónica / *See electronic signature*
20. Firma / *Signature*:
EL SUBDIRECTOR GENERAL DE CALIDAD Y SEGURIDAD INDUSTRIAL
Resolución P.D. del DIRECTOR GENERAL DE INDUSTRIA Y DE LA PYME de 25-10-2012
21. Los siguientes documentos, que llevan el número de homologación arriba indicado, pueden ser obtenidos a solicitud del interesado / *The following documents, bearing the approval number shown above, are available on request*:
 - * Informe técnico / *Technical report*
 - * Documentación técnica del fabricante / *Manufacturer's technical documentation*

(1) Táchese lo que no proceda / *Strike out what does not apply*

INFORME N° / REPORT No. MT16100097**CASCOS DE PROTECCIÓN Y SUS PANTALLAS PARA CONDUCTORES Y PASAJEROS DE
MOTOCICLETAS Y CICLOMOTORES SEGÚN EL REGLAMENTO 22.05
PROTECTIVE HELMETS AND THEIR VISORS FOR DRIVERS AND PASSENGERS OF MOTORCYCLES
AND MOPEDS ACCORDING TO REGULATION 22.05****EXTENSION II**

Fabricante / *Manufacturer* : JIANGMEN PENGCHENG HELMETS LTD.
No.01-7 Dongsheng Road, Gonghe Town, Heshan, Jiangmen City,
Guangdong, 529728 P.R. China

Marca(s) / *Make(s)* : MHR, LS2

Tipo / *Type* : FF352-1

Lugar y fecha de emisión del
informe / *Place and date* : L'Albornar, Santa Oliva (Tarragona)
05.12.2016

CONCLUSIONES: La modificación introducida en el casco, como se detalla en el anexo a este informe, es motivo de extensión de homologación respecto al casco tipo y extensión (exps. IDIADA N^{os} MT14060075 y MT14090083) y CUMPLE con las especificaciones relativas a la homologación de cascos y pantallas de protección para conductores y pasajeros de motocicletas y ciclomotores, correspondientes al Reglamento ECE 22.05. /

CONCLUSIONS: *Modification introduced to the helmet, as detailed in the annex to this report, grant grounds for approval extension with respect to formerly certified helmet-type and extension (IDIADA Reports Nos. MT14060075 and MT14090083), and FULFILS the specifications relating to the homologation of helmets and their visors of protection for drivers and passengers of motorcycles and mopeds, according to Regulation 22.05.*

Realizado / *Performed by* :

Daniel García-Maroto Fernández
TÉCNICO DE HOMOLOGACIONES
HOMOLOGATION TECHNICIAN

Vº. Bº. / *Revised by* :

Víctor Costa Escarrà
JEFE DE DEPARTAMENTO
DEPARTMENT MANAGER

* LOS RESULTADOS PRESENTADOS SE REFIEREN ÚNICAMENTE A LA MUESTRA ENSAYADA.
THE PRESENTED RESULTS REFER ONLY TO THE TESTED SAMPLE

* QUEDA TERMINANTEMENTE PROHIBIDA LA REPRODUCCION PARCIAL DE ESTE INFORME SIN PERMISO EXPRESO DE IDIADA.
THE PARTIAL REPRODUCTION OF THIS REPORT WITHOUT THE PERMISSION OF IDIADA IS COMPLETELY FORBIDDEN

ANEXO AL INFORME / ANNEX TO THE TEST REPORTMOTIVOS DE EXTENSIÓN / EXTENSION REASONS

- Cambio del PEE para todas las tallas / *Change of the EPS for all sizes*
- Inclusión del cierre micrométrico / *Inclusion of the micrometric buckle: No.15*

IDENTIFICACIÓN DEL CASCO PRESENTADO AL ENSAYO / IDENTIFICATION OF HELMET SUBMITTED FOR TEST

Fabricante /
Manufacturer : JIANGMEN PENGCHENG HELMETS LTD.
No.01-7 Dongsheng Road, Gonghe Town, Heshan, Jiangmen City,
Guangdong, 529728 P.R. China

Marca(s) / *Make(s)* : LS2

Tipo / *Type* : FF352-1

Tallas / *Sizes* : XXS(52), XS(54), M(58), XXL(61)

Id. de la muestra /
Sample Id. : CA1610/18

ESPECIFICACIONES GENERALES / GENERAL SPECIFICATIONS

1. Constitución básica /
Basic constructionCORRECT
2. Protección / *Protection*:
 - 2.1 Área cubierta por la carcasa /
Area covered by the shellCORRECT
 - 2.2 Área cubierta por el relleno protector /
Area covered by the protective paddingCORRECT
3. Proyecciones o irregularidades en la parte exterior de la carcasa /
Projections or irregularities in the outer shellCORRECT
4. Interior del casco /
Inside of helmetCORRECT
5. Sistema de retención protegido contra la abrasión /
Retention system protected against abrasionCORRECT

* LOS RESULTADOS PRESENTADOS SE REFIEREN UNICAMENTE A LA MUESTRA ENSAYADA.
THE PRESENTED RESULTS REFER ONLY TO THE TESTED SAMPLE

* QUEDA TERMINANTEMENTE PROHIBIDA LA REPRODUCCION PARCIAL DE ESTE INFORME SIN PERMISO EXPRESO DE IDIADA.
THE PARTIAL REPRODUCTION OF THIS REPORT WITHOUT THE PERMISSION OF IDIADA IS COMPLETELY FORBIDDEN

- 6. Sistema de retención / *Retention system*:
 - 6.1. Anchura de la cinta /
Chin strap widthCORRECT
 - 6.2. Cinta desprovista de mentonera /
Chin strap does not include a chin-cupCORRECT
 - 6.3. Dispositivo de ajuste y retención de la cinta /
Chin strap adjustment and tensioning device.....CORRECT
 - 6.4. Posición de los dispositivos de retención y ajuste de la cinta /
Position of the chin strap fastening and tensioning devicesCORRECT
 - 6.5. Dispositivo de apertura rápida con barra deslizante o doble anillo en D /
Sliding bar or double-D ring fastening devices:
 - 6.5.1. Sistema de retención de apertura involuntaria /
Free end retaining system.....NOT APPLICABLE
 - 6.5.2. Patilla de desenganche del mecanismo /
Releasing pulling flap.....NOT APPLICABLE
 - 6.6. Mecanismo de apertura rápida /
Quick release mechanism.....CORRECT
 - 6.7. Comportamiento del sistema de retención /
Retention system behaviour.....CORRECT
 - 6.8. Protección contra manipulación incorrecta del cierre /
Buckle protected against incorrect manipulation.....CORRECT
- 7. Estado del casco después del ensayo /
Helmet status after testCORRECT
- 8. Visión periférica / *Peripheral vision*:
 - Horizontal / *Horizontal* ($\geq 105^\circ$).....CORRECT
 - Hacia arriba / *Upwards* ($\geq 7^\circ$).....CORRECT
 - Hacia abajo / *Downwards* ($\geq 45^\circ$).....CORRECT

* LOS RESULTADOS PRESENTADOS SE REFIEREN ÚNICAMENTE A LA MUESTRA ENSAYADA.
THE PRESENTED RESULTS REFER ONLY TO THE TESTED SAMPLE

* QUEDA TERMINANTEMENTE PROHIBIDA LA REPRODUCCION PARCIAL DE ESTE INFORME SIN PERMISO EXPRESO DE IDIADA.
THE PARTIAL REPRODUCTION OF THIS REPORT WITHOUT THE PERMISSION OF IDIADA IS COMPLETELY FORBIDDEN

ENSAYO DE ABSORCIÓN DE IMPACTO / *IMPACT ABSORPTION TEST*

 TALLA / *SIZE*: XXL (61)

 Cabeza de ensayo / *Test headform*: M (60)

N° / <i>No.</i>	ACONDIC. / <i>CONDITIONING</i>	YUNQUE / <i>ANVIL</i>	VELOCIDAD / <i>SPEED</i> (m/s)	PUNTO IMPACTO / <i>IMPACT POINT</i>	RESULTADOS / <i>RESULTS</i>	
					Ac _(g) máx ≤ 275 g	HIC ≤ 2400
1	AMBIENTE / <i>AMBIENT</i>	PLANO / <i>FLAT</i>	7.5	B	200	1493
				X	251	2195
				P	208	1929
				R	214	1982
2	AMBIENTE / <i>AMBIENT</i>	CUÑA / <i>KERBSTONE</i>	7.5	B	187	1266
				X	183	1269
				P	169	1266
				R	158	1201
3	-20 °C	PLANO / <i>FLAT</i>	7.5	B	218	1749
				X	268	2279
				P	216	2032
				R	208	1645
			5.5	S	161	592
4	+50 °C	CUÑA / <i>KERBSTONE</i>	7.5	B	201	1279
				X	174	1198
				P	199	1396
				R	151	1160
5	UV + H ₂ O	PLANO / <i>FLAT</i>	7.5	B	206	1603
				X	253	2215
				P	209	1979
				R	215	1978

* LOS RESULTADOS PRESENTADOS SE REFIEREN UNICAMENTE A LA MUESTRA ENSAYADA.
THE PRESENTED RESULTS REFER ONLY TO THE TESTED SAMPLE

* QUEDA TERMINANTEMENTE PROHIBIDA LA REPRODUCCION PARCIAL DE ESTE INFORME SIN PERMISO EXPRESO DE IDIADA.
THE PARTIAL REPRODUCTION OF THIS REPORT WITHOUT THE PERMISSION OF IDIADA IS COMPLETELY FORBIDDEN

TALLA / SIZE: M (58)

Cabeza de ensayo / Test headform: J (57)

Nº / No.	ACONDIC. / CONDITIONING	YUNQUE / ANVIL	VELOCIDAD / SPEED (m/s)	PUNTO IMPACTO / IMPACT POINT	RESULTADOS / RESULTS	
					Ac _(g) máx ≤ 275 g	HIC ≤ 2400
6	-20 °C	PLANO / FLAT	7.5	B	205	1709
				X	246	2131
				P	195	2004
				R	196	1580
			5.5	S	195	542
7	+50 °C	CUÑA / KERBSTONE	7.5	B	143	1046
				X	201	1278
				P	155	1177
				R	134	908

TALLA / SIZE: XS (54)

Cabeza de ensayo / Test headform: E (54)

Nº / No.	ACONDIC. / CONDITIONING	YUNQUE / ANVIL	VELOCIDAD / SPEED (m/s)	PUNTO IMPACTO / IMPACT POINT	RESULTADOS / RESULTS	
					Ac _(g) máx ≤ 275 g	HIC ≤ 2400
8	-20 °C	PLANO / FLAT	7.5	B	208	1736
				X	244	2205
				P	191	1739
				R	193	1852
			5.5	S	58	130
9	+50 °C	CUÑA / KERBSTONE	7.5	B	138	1064
				X	197	1434
				P	159	1275
				R	140	1058

* LOS RESULTADOS PRESENTADOS SE REFIEREN ÚNICAMENTE A LA MUESTRA ENSAYADA.
THE PRESENTED RESULTS REFER ONLY TO THE TESTED SAMPLE

* QUEDA TERMINANTEMENTE PROHIBIDA LA REPRODUCCION PARCIAL DE ESTE INFORME SIN PERMISO EXPRESO DE IDIADA.
THE PARTIAL REPRODUCTION OF THIS REPORT WITHOUT THE PERMISSION OF IDIADA IS COMPLETELY FORBIDDEN

TALLA / SIZE: XXS (52)

Cabeza de ensayo / Test headform: A (50)

Nº / No.	ACONDIC. / CONDITIONING	YUNQUE / ANVIL	VELOCIDAD / SPEED (m/s)	PUNTO IMPACTO / IMPACT POINT	RESULTADOS / RESULTS	
					Ac _(g) máx ≤ 275 g	HIC ≤ 2400
10	-20 °C	PLANO / FLAT	7.5	B	217	1971
				X	243	2108
				P	186	1775
				R	217	2132
			5.5	S	72	202
11	+50 °C	CUÑA / KERBSTONE	7.5	B	151	1148
				X	191	1386
				P	168	1545
				R	174	1428

Resultado ensayo de absorción de impactos / Impact absorption test resultCORRECT

ENSAYO DINÁMICO DEL SISTEMA DE RETENCIÓN / RETENTION SYSTEM DYNAMIC TEST

CASCO / HELMET		DESPLAZAMIENTO / DISPLACEMENT	
Nº / No.	TALLA / SIZE	DINÁMICO / DYNAMIC (≤ 35 mm)	RESIDUAL / RESIDUAL (≤ 25 mm)
12	XXS (52)	33.2	13.4

ENSAYO DE DESCALCE / DETACHING TEST

CASCO / HELMET		ÁNGULO GIRADO / TURNED ANGLE (≤ 30°)
Nº / No.	TALLA / SIZE	
13	XXS (52)	28.3°

 Lugar del ensayo / Test place : L'Albornar, Santa Oliva (Tarragona)
 Fecha del ensayo / Test date : 25.10.2016-31.10.2016

 Daniel García-Maroto Fernández
 TÉCNICO DE HOMOLOGACIONES
 HOMOLOGATION TECHNICIAN

 * LOS RESULTADOS PRESENTADOS SE REFIEREN ÚNICAMENTE A LA MUESTRA ENSAYADA.
 THE PRESENTED RESULTS REFER ONLY TO THE TESTED SAMPLE

 * QUEDA TERMINANTEMENTE PROHIBIDA LA REPRODUCCION PARCIAL DE ESTE INFORME SIN PERMISO EXPRESO DE IDIADA.
 THE PARTIAL REPRODUCTION OF THIS REPORT WITHOUT THE PERMISSION OF IDIADA IS COMPLETELY FORBIDDEN

DOCUMENTACIÓN TÉCNICA /
TECHNICAL DOCUMENTATION



**R22.05/ECE TYPE-APPROVAL OF PROTECTIVE HELMETS AND THEIR VISORS FOR DRIVERS
AND PASSENGERS OF MOTORCYCLES AND MOPEDS**

INDEX OF DOCUMENTATION

<i>Page</i>	<i>Concept</i>	<i>Date</i>
1	GENERAL INFORMATION	OCT. 2014
2	DESCRIPTION OF THE HELMET / SHELL / <i>RETENTION SYSTEM</i>	<i>DEC. 2016</i>
3	<i>RETENTION SYSTEM / PROTECTIVE PADDING</i>	<i>DEC. 2016</i>
4	COMFORT PADDING / VISOR / ACCESSORIES	OCT. 2014
5	DRAWING OF THE HELMET WITH DIMENSIONS (Sizes XXL-XXS)	OCT. 2014
6	<i>DRAWING OF THE PROTECTIVE PADDING (Sizes XXL-L)</i>	<i>DEC. 2016</i>
7	<i>DRAWING OF THE PROTECTIVE PADDING (Sizes M-XS)</i>	<i>DEC. 2016</i>
8	<i>DRAWING OF THE PROTECTIVE PADDING (Size XXS)</i>	<i>DEC. 2016</i>
9	DRAWING OF THE RETENTION SYSTEM (No.15-1 buckle)	OCT. 2014
10	DRAWING OF THE RETENTION SYSTEM (No.17-1 buckle)	OCT. 2014
11	<i>DRAWING OF THE RETENTION SYSTEM (No.15 buckle)</i>	<i>DEC. 2016</i>
12	DRAWING OF THE VISOR (Variant FF-MHR-15)	OCT. 2014
13	USER INSTRUCTIONS (I)	OCT. 2014
14	USER INSTRUCTIONS (II)	OCT. 2014
15	USER INSTRUCTIONS (III)	OCT. 2014

Extension reasons:

- ***Change of the EPS for all sizes.***
- ***Inclusion of the micrometric buckle: No.15.***

Changes marked on blue, bold and italic characters.



**R22.05/ECE TYPE-APPROVAL OF PROTECTIVE HELMETS AND THEIR VISORS FOR DRIVERS
AND PASSENGERS OF MOTORCYCLES AND MOPEDS**

1. GENERAL INFORMATION

1.1 Make:

MHR, LS2

1.1.1. Commercial denominations:

1.2. Type:

FF352-1

1.3. Variants / Versions: -----

1.4. Name and address of manufacturer:

**JIANGMEN PENGCHENG HELMETS LTD.
No.01-7 Dongsheng Road, Gonghe Town, Heshan, Jiangmen City,
Guangdong, 529728 P.R. China**

1.5. If any, name and address of manufacturer's authorized representative: ----

1.6. Location and method of affixing of the international approval mark:

Marked in a label sewn on the retention system chin strap

1.7. Number of visors which can be fitted:

1



**R22.05/ECE TYPE-APPROVAL OF PROTECTIVE HELMETS AND THEIR VISORS FOR DRIVERS
AND PASSENGERS OF MOTORCYCLES AND MOPEDS**

2. DESCRIPTION OF THE HELMET

2.1. Type of helmet: **Full face / Flip-up / Open face**

2.2. Type of lower face cover: **"P" protective / "NP" non protective / "J" none**

2.3. Sizes:

XXS(52cm), XS(54cm), S(56cm), M(58cm), L(60cm), XL(61cm), XXL(61cm)

3. SHELL

3.1. Material used:

ABS

3.2. Composition of the border join on the shell:

PVC

3.3. Ventilations:

3.3.1. Number of ventilations: **3pcs**

3.3.2. Positioning on the shell: **1pcs mouth vent, 1pcs front vent, 1pcs rear top vent**

4. RETENTION SYSTEM

4.1. Chin strap:

4.1.1. Material:

NYLON

4.1.2. Width:

22 mm when use Quick release mechanisms (No 15-1, No 17-1 and *No 15⁺ buckles*)

**R22.05/ECE TYPE-APPROVAL OF PROTECTIVE HELMETS AND THEIR VISORS FOR DRIVERS
AND PASSENGERS OF MOTORCYCLES AND MOPEDS**

4.2. **Retention system:**

Quick release mechanisms (No.15-1, No.17-1 and No.15)

4.3. Comfort padding of the retention system:

4.3.1. Composition: **Leather and textile.**

4.3.2. Thickness: **3 mm**

4.4. Fixing system to the shell:

By means of a metallic piece fixed to the shell by rivets.

5. PROTECTIVE PADDING

5.1. Composition: **Expanded polystyrene**

5.2. **Density:**

Size	Main Part Kg/m ³	Top Part Kg/m ³	Side + Chin Part Kg/m ³
XXS	45	20	40
XS	45	20	55
S			
M			
L	55	20	80
XL			
XXL			

5.3. **Weight:**

Size	Main Part	Top Part	Side + Chin Part Kg/m ³
XXS	111g±5g	11g±2g	36g±2g
XS	111g±5g	11g±2g	50g±2g
S			
M			
L	128g±5g	11g±2g	68g±2g
XL			
XXL			



**R22.05/ECE TYPE-APPROVAL OF PROTECTIVE HELMETS AND THEIR VISORS FOR DRIVERS
AND PASSENGERS OF MOTORCYCLES AND MOPEDS**

6. COMFORT PADDING

6.1. Composition of:

Comfort padding: **Sponge**

Comfort tissue: **Nylon**

Protection of the back of the neck: **Sponge, textile and leather.**

7. VISOR

7.1. Approval number: **E9-05.1551**

7.2. Make:

**MHR, TAKACHI, G-MAC, NITRO, IXS, SYKO, LS2, SHAD, SWIFT, GPX, TEXX,
NEXO, BOX, TUZO, MAC, A-PRO**

7.3. Type: **FF-MHR-15 (Variant FF-MHR-15)**

7.4. Name and address of manufacturer:

**JIANGMEN PENGCHENG HELMETS LTD.
No.01-7 Dongsheng Road, Gonghe Town, Heshan, Jiangmen City,
Guangdong, 529728 P.R. China**

7.5. Material: **PC**

7.6. Drawing of the visor: **See page 12.**

7.7. Surface treatment: **Anti-scratch treatment.**

7.8. Colour: **Clear**

7.9. Manufacturing method: **Mould injection.**

8. ACCESSORIES

8.1. User instructions:

8.1.1. Text: **See pages 13,14 and 15.**

8.1.2. Location: **Hang on chin strap.**



**R22.05/ECE TYPE-APPROVAL OF PROTECTIVE HELMETS AND THEIR VISORS FOR DRIVERS
AND PASSENGERS OF MOTORCYCLES AND MOPEDS**

DRAWING OF THE HELMET WITH DIMENSIONS (Sizes XXL-XXS)

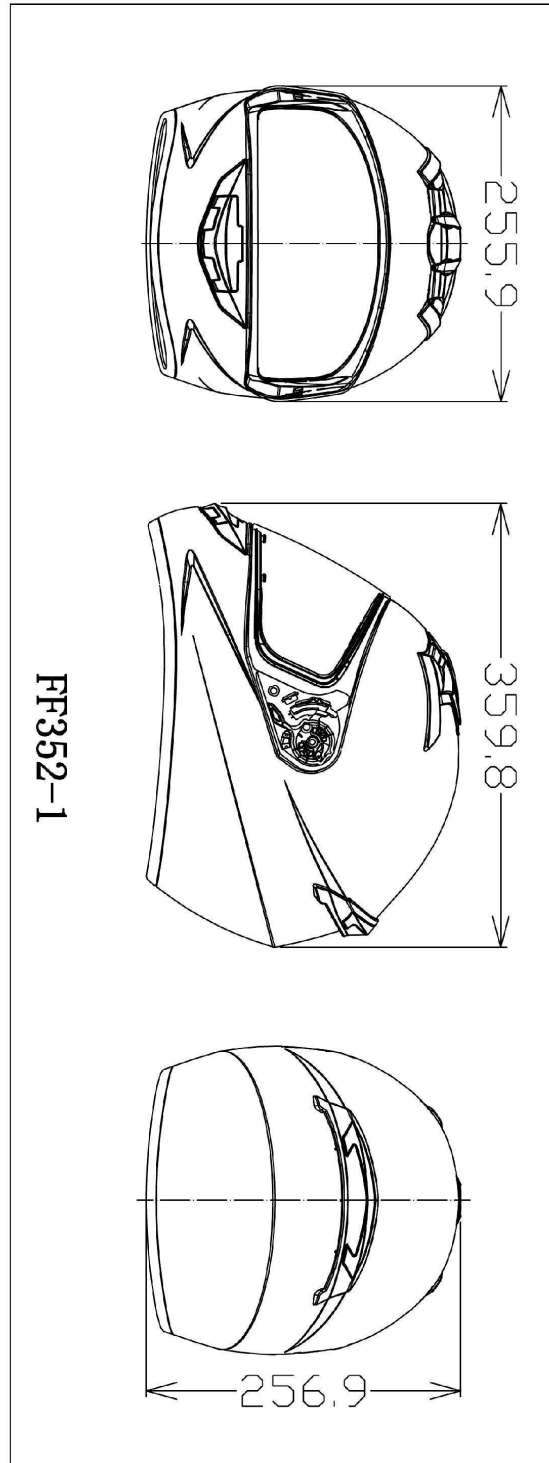



R22.05/ECE TYPE-APPROVAL OF PROTECTIVE HELMETS AND THEIR VISORS FOR DRIVERS AND PASSENGERS OF MOTORCYCLES AND MOPEDS

DRAWING OF THE PROTECTIVE PADDING (Sizes XXL-L)

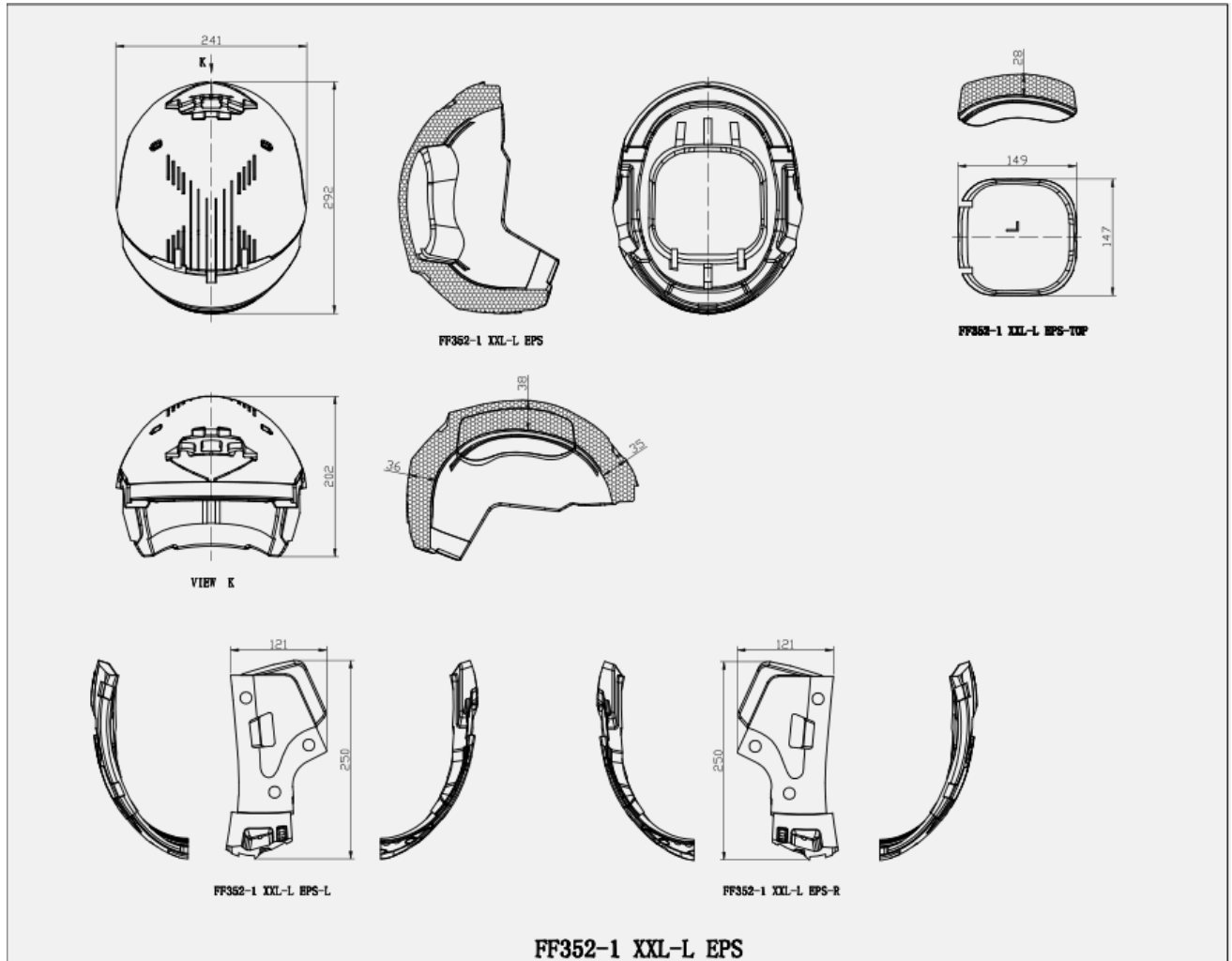



R22.05/ECE TYPE-APPROVAL OF PROTECTIVE HELMETS AND THEIR VISORS FOR DRIVERS AND PASSENGERS OF MOTORCYCLES AND MOPEDS

DRAWING OF THE PROTECTIVE PADDING (Sizes M-XS)

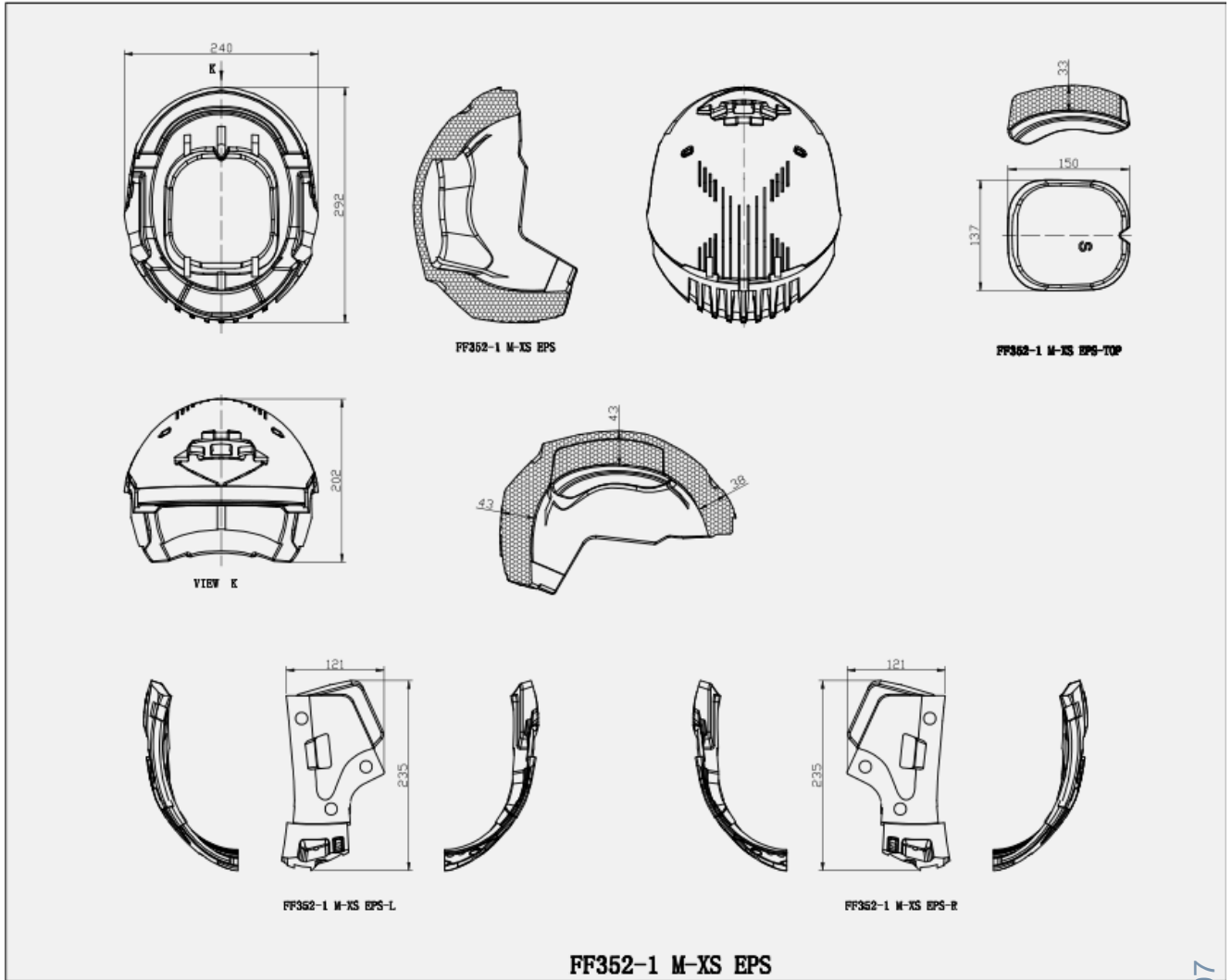



R22.05/ECE TYPE-APPROVAL OF PROTECTIVE HELMETS AND THEIR VISORS FOR DRIVERS AND PASSENGERS OF MOTORCYCLES AND MOPEDS

DRAWING OF THE PROTECTIVE PADDING (Sizes XXS)

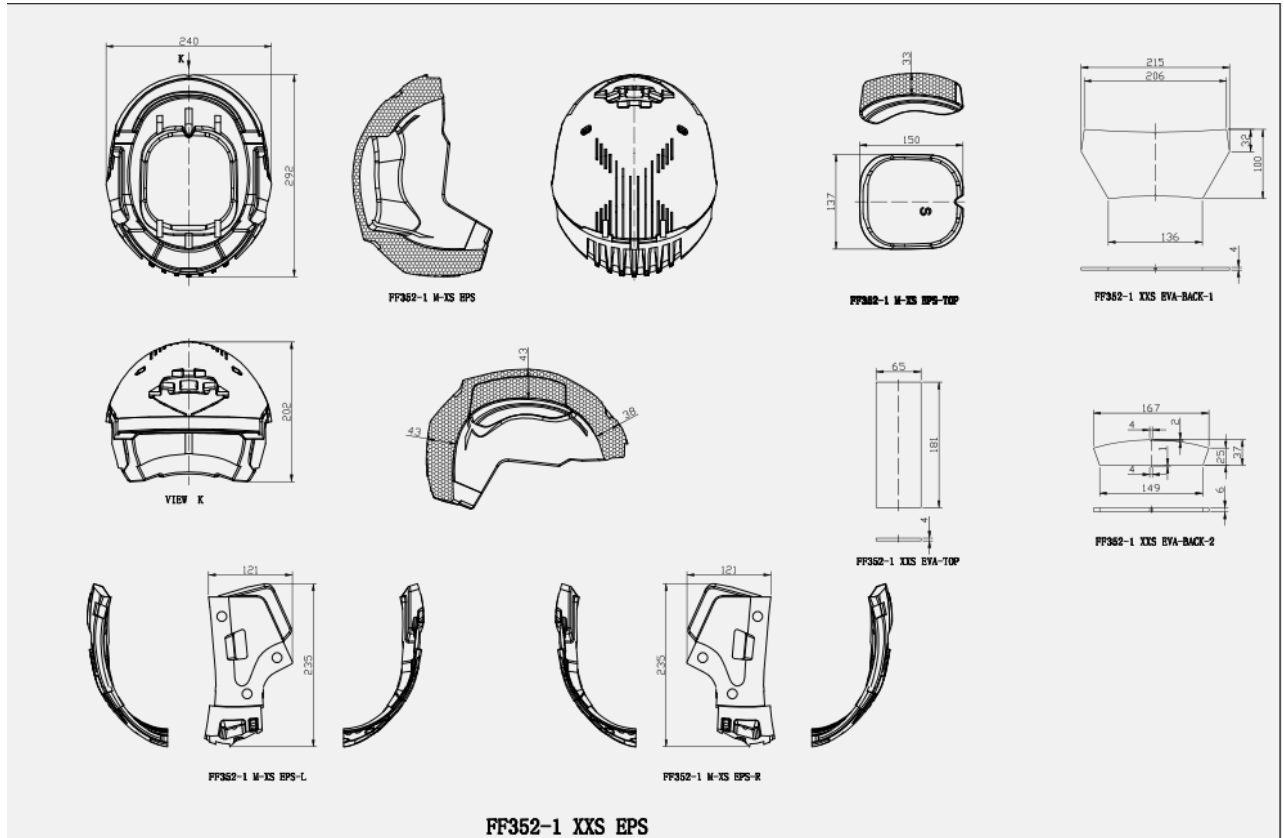

R22.05/ECE TYPE-APPROVAL OF PROTECTIVE HELMETS AND THEIR VISORS FOR DRIVERS AND PASSENGERS OF MOTORCYCLES AND MOPEDS

DRAWING OF THE RETENTION SYSTEM (No.15-1 buckle)

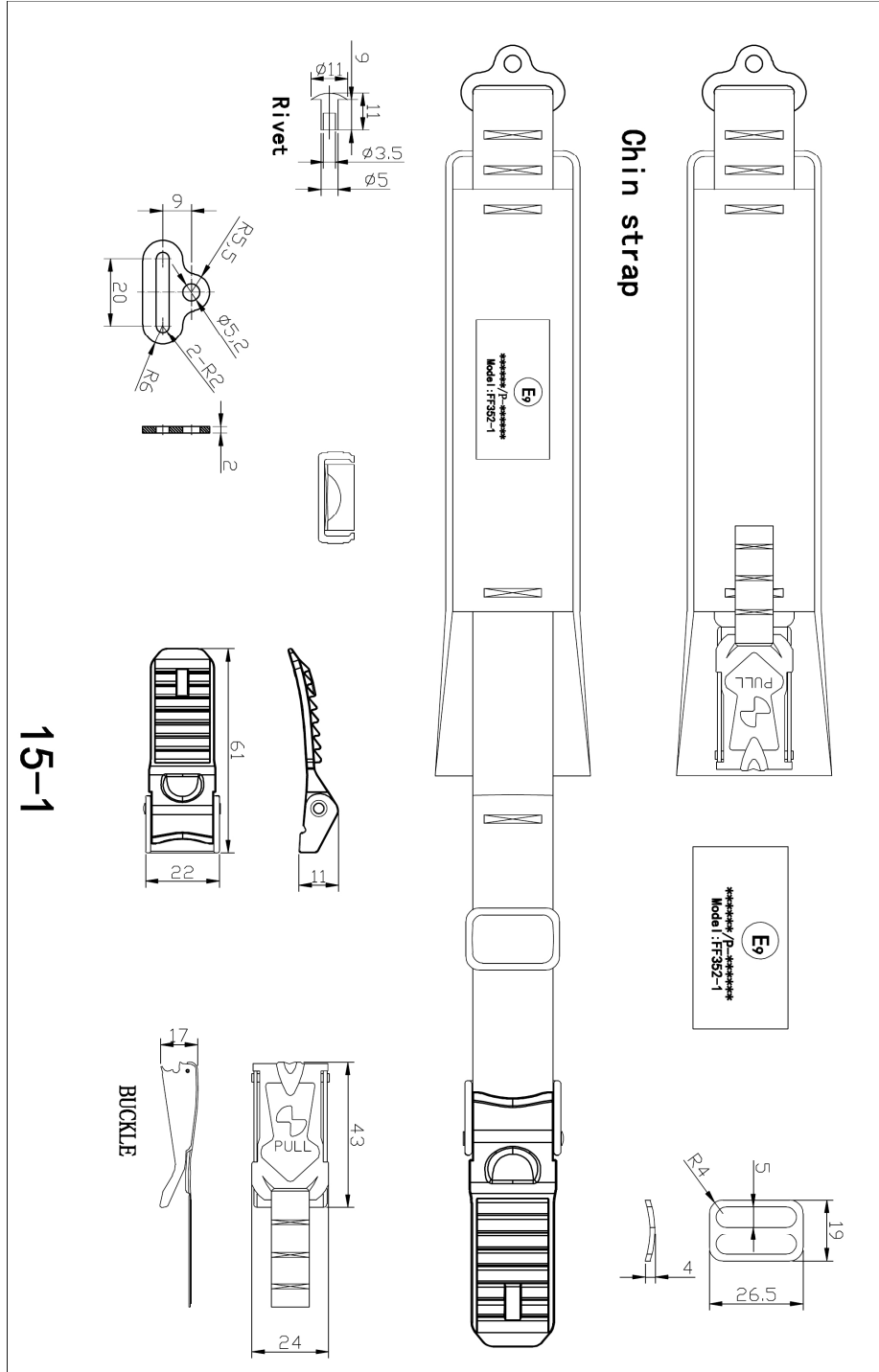



R22.05/ECE TYPE-APPROVAL OF PROTECTIVE HELMETS AND THEIR VISORS FOR DRIVERS
 AND PASSENGERS OF MOTORCYCLES AND MOPEDS

DRAWING OF THE RETENTION SYSTEM (No.17-1 buckle)

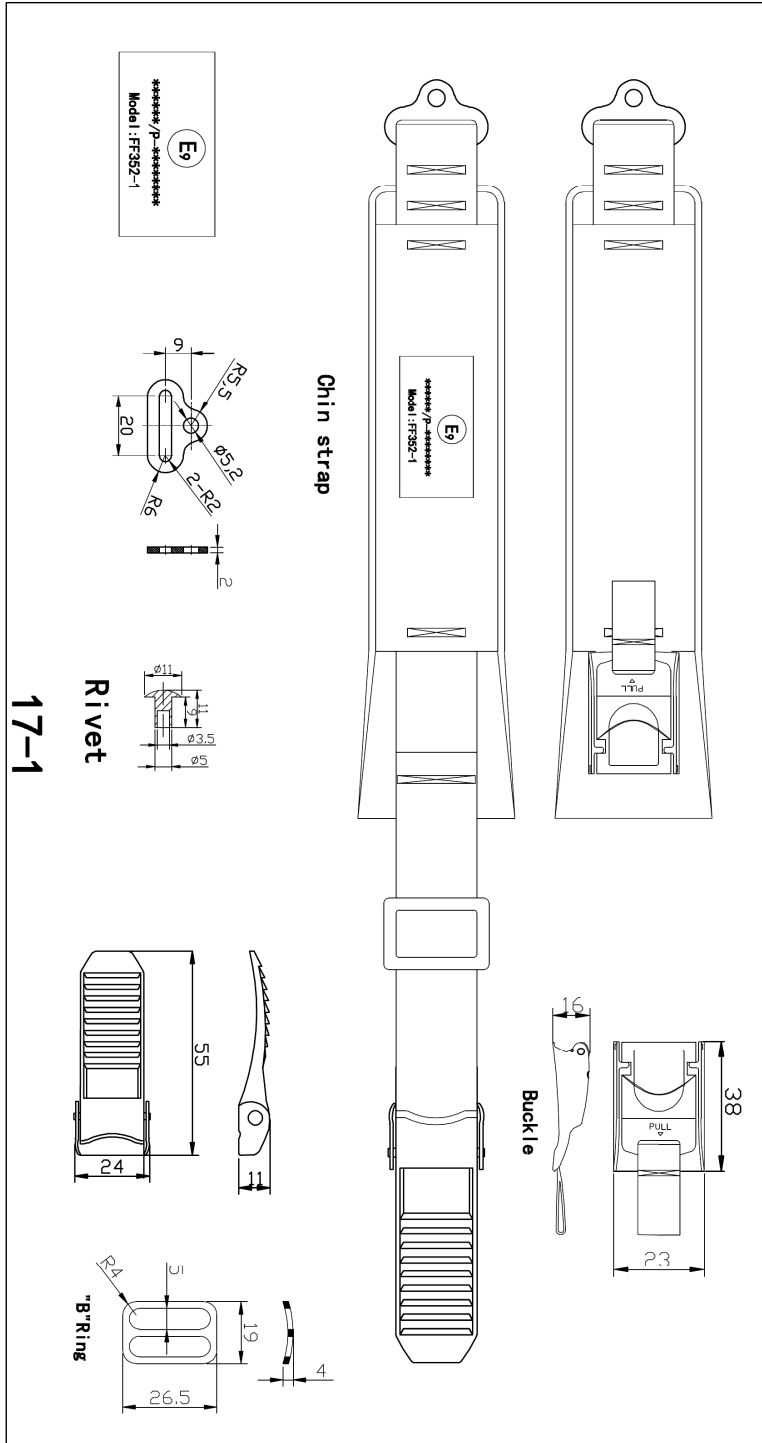



**R22.05/ECE TYPE-APPROVAL OF PROTECTIVE HELMETS AND THEIR VISORS FOR DRIVERS
AND PASSENGERS OF MOTORCYCLES AND MOPEDS**

DRAWING OF THE RETENTION SYSTEM (No.15 buckle)

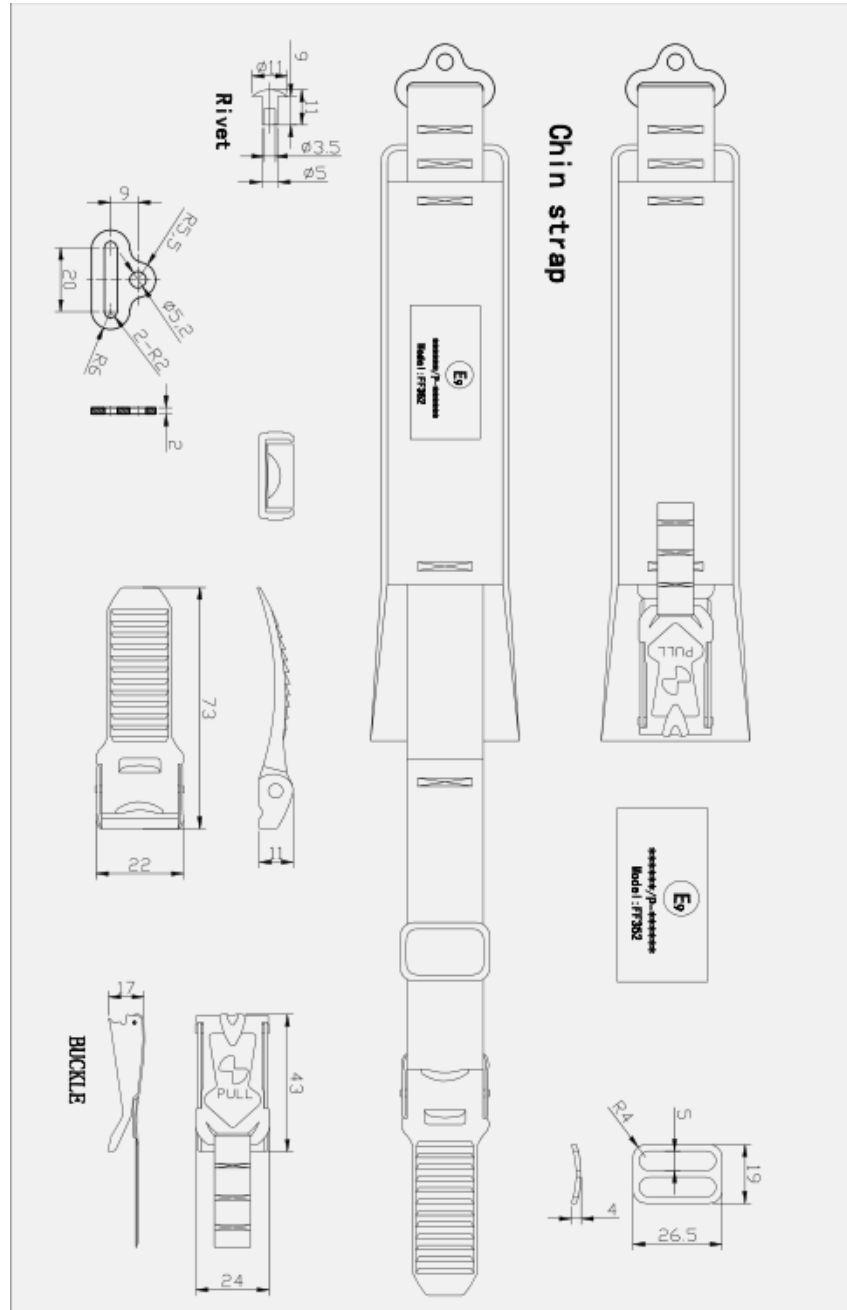



**R22.05/ECE TYPE-APPROVAL OF PROTECTIVE HELMETS AND THEIR VISORS FOR DRIVERS
AND PASSENGERS OF MOTORCYCLES AND MOPEDS**

DRAWING OF THE VISOR

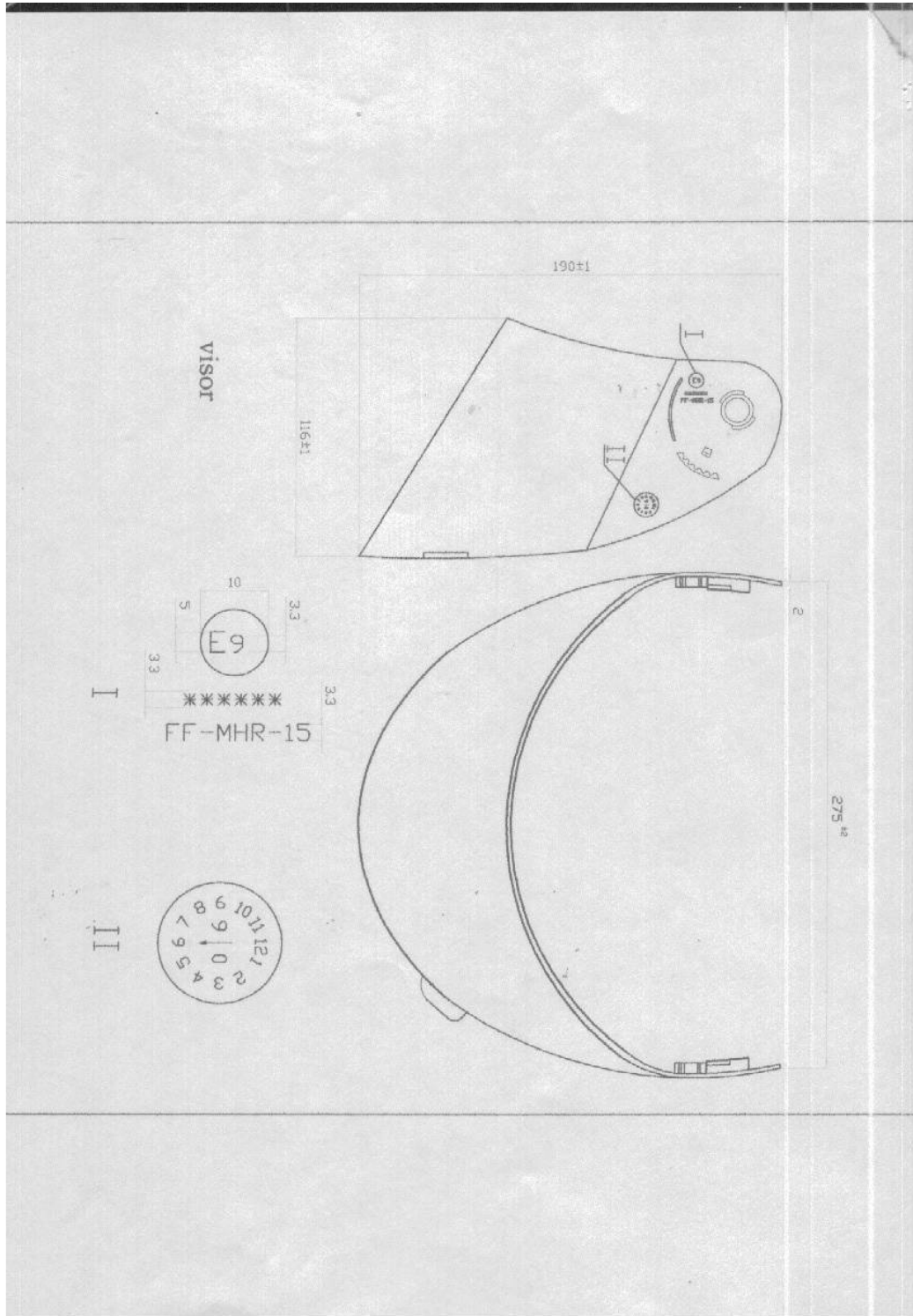



R22.05/ECE TYPE-APPROVAL OF PROTECTIVE HELMETS AND THEIR VISORS FOR DRIVERS AND PASSENGERS OF MOTORCYCLES AND MOPEDS

USER INSTRUCTIONS (I)

Congratulations on purchasing your new **LS2** helmet. Please read these instructions carefully before use. They contain valuable informations to help you obtain the most protection from your helmet and to ensure a longer life for your helmet. All our products come from the most advanced research in terms of active security and design. The very high level for aerodynamism and comfort will get you the best performances all along the road. Whatever can be your choice leisure, tourism, racing, one of the helmets from the LS2 range is the best solution for your active protection.

1. Read these instructions thoroughly before using your helmet for the first time and store them safely for future reference.
2. A helmet like all products may wear out over time depending upon its use and the amount of care that is given. Please check your helmet every time before use for damage and do not use a damaged helmet. The most known standards of homologation recommend a helmet life of five years. LS2 agrees with their recommendation even though your helmet does not show any signs of malfunction, visible damage or defect. We strongly recommend you replace your helmet five years after the original date of purchase. See also "ONE IMPACT RULE" of item 3 in this manual, which says clearly "helmet is designed to help absorb one impact".
3. If you have any questions or comments concerning this helmet, please contact your nearest LS2 dealer or agent. Note that these specifications are subject to change without notice, as we continually strive to improve our products.

HOW TO CHOOSE A HELMET AND WEAR IT CORRECTLY

No helmet can protect the wearer against all foreseeable high speed and low speed impact, however, for maximum head protection the helmet must be of proper fit and the retention system must be securely fastened under the chin. Failure to have proper fit and to securely fasten the helmet is dangerous as the helmet could come off in an accident resulting in severe head injury or death.

1 To determinate proper fit.

- 1.1. Measure your head size. Wrap a tape measure horizontally around your head at the height of about 2,5 cm above your eyebrows. This will establish the longest measurement around your head.
- 1.2. Select the helmet that is the closest match to your head size. If your head size should fit between two helmet sizes, try on the smaller one first.

2 Try the helmet on

- 2.1. Expand the helmet opening by the straps, and slide your head into the helmet. Pull the chin straps only, not the chin straps cover, pulling on the covers may rip them. If the helmet is not tight, it is too big for you. If you are unfamiliar with helmets you may be reluctant to pull down the helmet which should feel tight. Even if you feel it is difficult to put it on, please use the smallest helmet possible.

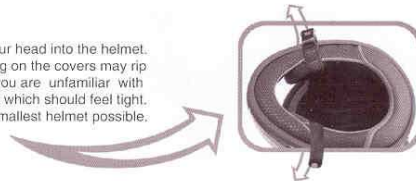

3 Check for a proper fit. With the helmet, go through the following checklist to determine whether the helmet is the correct size.

- 3.1. Make sure the inner lining fits snugly all around your head.
- 3.2. Make sure the top pad presses closely to the top of your head.
- 3.3. Check whether the cheek pads are in contact with your cheeks.
- 3.4. Make sure there is no space between inner lining and brow where you could insert your finger.
- 3.5. Now, take hold of the helmet with a hand on each side. Without moving your head, try to move the helmet up and down, and side to side. You should feel the skin of your head and face being pulled as you try to move the helmet. If you can move the helmet around easily, it is too big. Try a smaller size.



4 Check the retention system and go through the following steps.

- 4.1. Fasten the chinstrap as tight as possible without causing you pain (see diagram 2). There must be no slack in the strap and it must be tight up against your chin.
- 4.2. With the chinstrap secured, put your hands flat on the back of the helmet and try to push the helmet off by rotating forward.
- 4.3. Next, put your hands on the front of the helmet above your forehead (or on the chinguard) and try to push the helmet off by rotating it toward the rear.
- 4.4. If the helmet starts to come off in either direction, do not use the helmet, either the helmet is too large for you or the chin strap is not tightened enough.

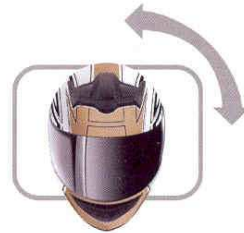

Tightening the chinstrap correctly is extremely important. Try to pull down on the chinstrap with the tips of your fingers if the strap is not against your chin or loosens, you have not properly put the strap through the D rings. Start again (see diagram 2) if your chinstrap is loose, the shock of an impact may knock your helmet off, leaving your head completely unprotected. Do not use a helmet that can be rolled off the head with the chinstrap fastened, since it may come off in an accident, resulting in death or serious personal injuries.



ENGLISH



**R22.05/ECE TYPE-APPROVAL OF PROTECTIVE HELMETS AND THEIR VISORS FOR DRIVERS
AND PASSENGERS OF MOTORCYCLES AND MOPEDS**

USER INSTRUCTIONS (II)

D RING: To securely fasten the D ring retention system, thread the end of the chinstrap through the D rings only as shown in diagram 2 and put it tight against your throat. Clip the chin strap end hook on the D ring as shown in diagram 2 to secure the loose end of the chin strap after it's securely fastening the chin strap. The only function of the chinstrap end hook fitted on the end of the chinstrap is to avoid fluttering of the end part of the chinstrap.

Quick-release retention system: To fasten the strap, push the metal tongue firmly into the buckle until it locks with a click. Pull the strap tight and pass the end of the strap through the strap ring or ladder to secure it. To release the strap, press the two catches inward (or slide the catches down).

SAFETY RECOMMENDATIONS

1

No helmet can protect wearer against all foreseeable high speed and low speed impacts.

However, for maximum head protection, the helmet must be of proper fit and retention system must be securely fastened under the chin. The helmet should allow peripheral vision when secure on your head. If your helmet is too large, it may sleep or move on your head while riding which may make it possible for your helmet to come off in an accident or to obstruct your vision while riding. In the first case, your helmet will not protect your head in an accident, which can result in serious personal injury or death and in the second case, if you cannot see you may have an accident.

2

Use only a helmet that fits snugly all around your head, and fasten the chinstrap securely under your chin.

Expand the helmet opening with your hands, and slide your head into the helmet. Please check whether the helmet fits properly according to the checklist (paragraph 3, page 3). Pull the chinstraps only, not the chinstraps covers. Pulling on the covers may rip them, if the helmet is not tight, it is too big for you. To securely fasten the D ring retention system, thread the end of the chinstrap through the D rings only as shown, and pull it tight up against your throat. In the case of quick-release retention system, refer to upper paragraph. If your chinstrap is loose, the shock of an impact may knock your helmet off leaving your head completely unprotected resulting in serious personal injury or death.

3

Helmets are designed to help absorb ONE impact. After your helmet has protected you from an impact, you must get a new one.

Your helmet is designed to distribute the force incurred during an impact over a wide area. Even if your helmet looks undamaged, externally its useful life is finished after one impact during riding, for example, a capsiz or accident where you and your helmet hit the ground or some object. In an impact, the helmet's impact absorbing liner becomes compacted. Once this has happened, the helmet no longer has the ability to absorb further impacts. Your helmet may look the same, but it will not provide protection in an accident. If you have any doubts, for example, if you drop your helmet or if it is hit by something and you are not sure if this one impact rule applies, consult your LS2 dealer before you use the helmet again.



page 4

4

Clean your helmet carefully.

Never use hot or salt water, benzene, gasoline, glass cleaner or other solvents. Your helmet could be seriously damaged by these substances, without showing any apparent visible damage. A helmet damaged or weakened by a cleaning agent may not provide head protection in an accident resulting in serious personal injury or death. The correct way to clean a helmet is to mix 5 or 6 drops of mild soap in a quart of warm water. Dampen a soft cloth with this solution and wipe the helmet clean. Rinse with a wet cloth.

5

Never modify your helmet.

It is very dangerous to drill holes or cut the shell and /or the shock absorber liner. Modifications can seriously weaken the helmet. Modifying the retention system weakens it, and it may snap in an impact, removing parts such as the mouth guard or rubber face trim can expose edges, which may injure you in an accident. Always used approved LS2 parts when replacing shields, screws, or any other parts. A weakened helmet will not provide protection.

6

Don't mistreat your helmet.

Never ride with the helmet hanging from the helmet holder, and don't hang the helmet from angled supports like a mirror. Don't sit on your helmet or throw it around. You should not expose the liner of your helmet to strong sunlight and excessive heat such as near heaters or where temperatures exceed 50° C (122 F). Avoid the spray of insect repellent chemicals (such as "naphthalene") near the helmet. Mistreating your helmet will damage the shell and impact absorbing liner and reduce the helmet's ability to protect you in an accident.

7

Always check your helmet before riding off.

1. Check the shield and visor screws, and retighten them if necessary.
2. Check for cracks in the helmet. Strong acid (for exampl, battery acid) can damage the shield base. If you find cracks or damage, stop using the helmet immediately.
3. Plastic componets may start to wear out about 5 years after manufacture. If you find deterioration in any part of a component, either replace that component or get a new helmet. If these parts come loose and / or fall off while you are riding, your vision may be blocked which could cause an accident resulting in serious personal injury or death.
4. Check the security of the retention system
5. Make sure that the center pad (or comfort liner) and the cheek pads are attached before you use the helmet.

page 5



ENGLISH



**R22.05/ECE TYPE-APPROVAL OF PROTECTIVE HELMETS AND THEIR VISORS FOR DRIVERS
AND PASSENGERS OF MOTORCYCLES AND MOPEDS**

USER INSTRUCTIONS (III)

8

Maintain your helmet shield in good condition.

If your shield becomes too scratched or undeanable, replace it with a new one. Impaired visibility causes accidents. Clean your shield with mild soapy water, rinse well with clean water, and dry with a soft cloth. Never use benzene gasoline, glass cleaner or any other solvents. Do not attach stickers or adhesive tape to the shield, as this will weaken the hard coating. This can damage the shield. Do not drive with a dim or blurred face shield. Impaired vision can cause an accident resulting in serious personal injury or death.

9

Do not repaint the helmet.

We do not recommend you repaint the helmet, because paint and thinner can damage the materials used in the helmet construction. A helmet damaged weakened by a paint agent may not provide head protection in an accident resulting in serious personal injury or death. If you must paint your helmet, please consult your LS2 dealer.

10

Remember: helmets block important sounds and reduce awareness of environmental changes.

When you wear a helmet, especially a full-face type, you are somewhat isolated from the environment around you. Weather changes can catch you unprepared: sudden showers or temperature variations as you enter or leave tunnels or climb mountain roads can cause unexpected misting of your shield and loss of visibility. Do not drive with a fogged face shield. Wearing a helmet also reduces your ability to hear traffic sounds, especially of high speed. With a full face helmet, opening and closing the shield makes a major difference in how much you can hear. For safe riding be aware of how your helmet type, your speed, affects your perception of road conditions and whether your shield is open.

